

# OPERATION MANUAL

## NTF-15 Plus

### Nitrogen Tire Filling



Valve Stem Caps (Qty=200)

Order P/N 436075



**RTI Technologies, Inc**

10 Innovation Drive

York, PA 17402

800-468-2321

[www.rtitech.com](http://www.rtitech.com)

035-81263-00 (Rev B)

# TABLE OF CONTENTS

Pictograms .....	1
Health, Safety and Environmental Aspects .....	1
Description of the NTF-15 Plus Membrane .....	2
Process Parameters .....	3
Unpack & Check Equipment .....	3
Safety Precautions .....	4
Operation .....	4
Testing Nitrogen Purity .....	6
Maintenance .....	7
Parts Identification .....	8
Flow Diagram .....	9

## **Normal Operation – Loss of Pressure**

Nitrogen is generated by the NitroPro and retained in the storage tank. Nitrogen generation stops when this tank fills to the specified design pressure.

The pressure in the NitroPro storage tank may drop after extended non-use (over night for example). This is normal, and is similar to air compressors that will periodically cycle on to replenish pressure lost in the air storage tank and attached delivery system. Permeation through service hoses, fill nozzles, valves and other components directly associated with nitrogen generation is to be expected, and does not impact normal operation.

It may take a few minutes to replenish the pressure in the storage tank to maximum next time the NitroPro is used. This is normal.

# PICTOGRAMS

In this manual the following pictograms are used:



## Warning

A warning shows a hazard that can cause death or serious injury. Follow the instructions.



## Caution

A caution shows a danger that can cause damage to the equipment. Follow the instructions.



## Warning

Risk of death due to suffocation.



## Risk of fire

Oxygen-enriched air leads to an increased risk of fire in the event of contact with flammable products.



## High pressure risk

Follow the instructions with respect to compressed gasses.



Instructions with respect to the environment.

# HEALTH, SAFETY AND ENVIRONMENTAL ASPECTS

## General

Correct use of the NTF-15 Plus nitrogen generator is important for your personal safety and for trouble-free functioning. Incorrect use can cause damage to the NTF-15 Plus or can lead to incorrect gas supply to the customer's process.

## Warning



Read this manual before you start operating the NTF-15 Plus. Prevent accidents and damage.

Contact RTI if you detect a problem that you cannot solve with this manual.

## Compressed air

## Warning



Ensure that the feed air pressure can not exceed 190 psig.



## Nitrogen and Oxygen

The NTF-15 Plus generates nitrogen as a product. Oxygen enriched air is released as waste.



### Warning

Nitrogen can cause suffocation! Oxygen-enriched air leads to increased risk of fire in the event of contact with flammable products. Make sure that there is adequate ventilation at all times!

Do not install the NTF-15 Plus in an area where explosive substances may be present.

## DESCRIPTION OF THE NTF-15 Plus MEMBRANE

### General

The NTF-15 Plus separates compressed air into nitrogen and an oxygen enriched air stream. The separation system is based on membrane technology. The compressed air comes from a central system or from a dedicated compressor.

The nitrogen produced is stored in the nitrogen storage vessel. The NTF-15 Plus then switches on and off, depending on the nitrogen demand.

### Separation Principle

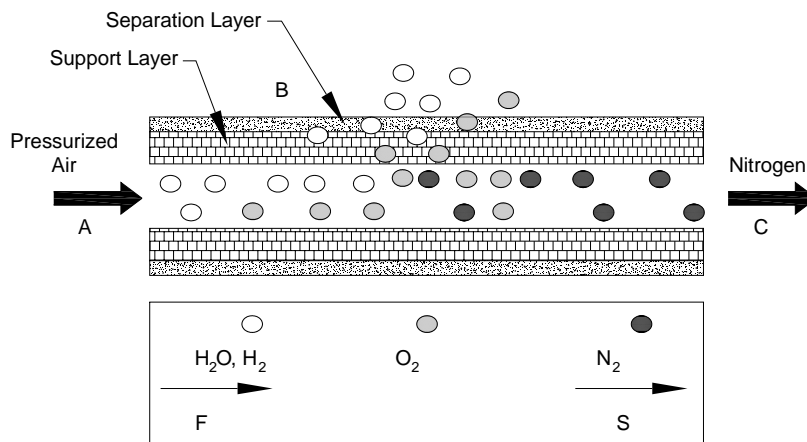

- |   |                       |   |      |
|---|-----------------------|---|------|
| A | Pressurized air inlet | F | Fast |
| B | Hollow fibre membrane | S | Slow |
| C | Nitrogen outlet       |   |      |

Ambient air contains nitrogen (78.1%), oxygen (20.9%), argon (1%), carbon dioxide, water vapor and traces of other inert gasses. Pressurized air (A) is fed through the hollow fiber membrane (B). The various air components diffuse through the wall of the membrane.

The diffusion rate differs for the various gasses:

Oxygen and water vapor have a high diffusion rate and permeate rapidly through the membrane wall.

Nitrogen has a low diffusion rate and permeates slowly through the membrane wall.

At the exit of the membrane (C), pressurized nitrogen is released.

# PROCESS PARAMETERS

The nitrogen production depends on these parameters:

- Flow rate** The lower the flow rate of compressed air through the hollow fiber membrane, the more oxygen can permeate through the membrane wall. As a result, the nitrogen produced at the outlet will have a higher purity. Nitrogen purity can be adjusted with the flow control valve.
- Temperature** The NTF-15 Plus operates at a temperature between 40-110°F (70-80°F optimally). If the temperature increases, the pressurized air consumption will also increase. Do not place the system in a room where the temperature may rise unnecessarily high.  
Allow enough piping between the compressor exit and the NTF-15 Plus inlet so that the hot compressed gas has time to cool within the specifications listed in this manual.
- Membrane pressure** A higher membrane pressure will increase the capacity (i.e. nitrogen output) of the NTF-15 Plus. Pressure also enables operation of the pneumatic pressure switch.
- External pressure** There must be atmospheric pressure at the outlet. The capacity and the purity of the nitrogen gas decreases strongly if the vent pressure exceeds the atmospheric pressure.



## Clean Shop Air – Proper Flow & Pressure

Many shop air supplies have an oiler installed to provide lubrication for air tools. The life of the filters in the NitroPro will be increased if the shop air supply is free from moisture and oil.

Recommendation - install a separate air line without an oiler to connect to the NitroPro. If this is not practical, consider installing a separate pre-filter before connecting the NitroPro to limit potential contamination to the NitroPro filters.

Also, ensure the shop air supply meets the pressure and flow ratings stated in the NitroPro Operation Manual for maximum nitrogen generation.

## ... IMPORTANT ...

**The condition of the Filter Element (mounted on rear of unit) can only be checked when shop air is connected to the unit and it is in the FILL TIRE mode of operation with Nitrogen being generated and filling the tank. It may be necessary to press the trigger on the fill wand to cause the tank filling. At all other times the Indicator will not be visible.**

**The Filter Element must be changed when the indicator moves into the CHANGE area and at least annually to protect the membrane warranty.**

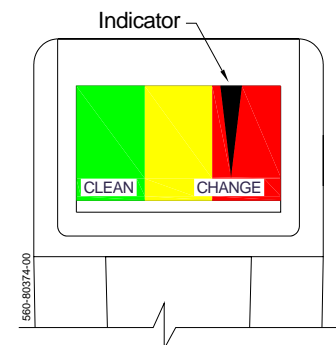

## UNPACK & CHECK EQUIPMENT

Ensure that all components were delivered.

Ensure that the compressed air source meets specification:

- Oil content of the compressed air is below 0.01mg/m<sup>3</sup>.
- Ensure that the compressed air pressure and quality is always as prescribed.
- Ensure that the air capacity is sufficient.

# SAFETY PRECAUTIONS



## Warning

Ensure there is sufficient ventilation.

Only feed the NTF-15 Plus with air.



Keep the air feed to the NTF-15 Plus clean and free of vapors of organic solvents and other contaminants.  
Do not place the NTF-15 Plus in a room where organic solvent vapors may be present.



Keep the ambient temperature between 40 and 110 °F. Do not connect hot compressed air directly from a compressor to the inlet of the NTF-15 Plus.

Regular maintenance should be performed on the NTF-15 Plus to ensure proper and safe operation.

Ensure that instructions concerning health and safety are compliant with local regulations.

## Environmental Aspects



The use and maintenance of the NTF-15 Plus do not include environmental dangers. Most parts are made of metal and can be disposed of in a manner consistent with local regulations.

Make sure that instructions concerning health, safety and environment are compliant with all local regulations.

# OPERATION



## Foreign Substances in Tires

Tires which have been in service may contain foreign substances such as leak sealers. It is important that these substances are not pulled into the NitroPro unit during the vacuum procedure, resulting in possible performance issues and costly repairs not covered by RTI's warranty.

When servicing a vehicle, first check the valve stems and valve stem caps for any type of fluid or foreign substance. Install deflators and allow all four tires to deflate to zero pressure. Then check the deflators for any indication of fluids or foreign substances.

Do not use the NitroPro vacuum procedure on any tire where evidence of fluids or foreign substances are detected on the valve stems, valve stem caps or deflators. Instead, follow a four step "deflate-inflate-deflate-inflate" process to achieve desired nitrogen purity.

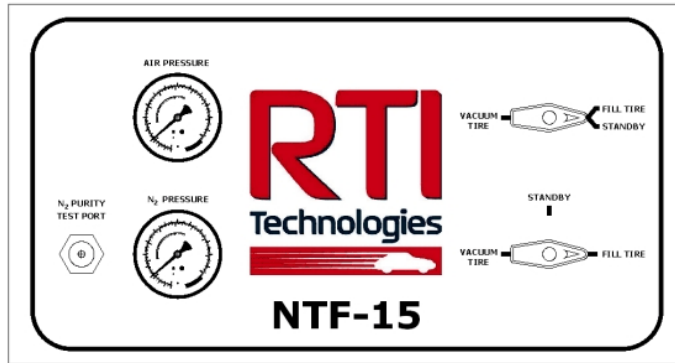

## Vacuum Tire

1. Install deflators and **check for foreign substances as explained on the preceding page.**
2. Connect shop air to the air inlet port on the rear of the NTF-15 Plus. Verify pressure indicated on panel mounted Air Pressure gauge is between 120 - 150 PSI.
3. Turn both panel valves to VACUUM TIRE.
4. Remove deflator and connect Pressure Gauge (on the end of the NTF-15 Plus coiled green hose) to the tire valve stem. Squeeze handle to vacuum the tire. Periodically release the handle to observe the vacuum level. **Do not vacuum to a level where the tire starts to deform.**

If your application requires an inlet pressure of 100 - 119 PSI, an adjustment to the automatic pressure switch may be required.  
 Contact RTI Technical Support at 800-468-2321 for further details

## Fill Tire

1. Connect shop air to the air inlet port on the rear of the NTF-15 Plus. Verify pressure indicated on panel mounted Air Pressure gauge is between 120 - 150 PSI. Verify Nitrogen pressure indicated on the panel mounted N<sub>2</sub> Pressure gauge is adequate for service.
2. Turn both panel valves to FILL TIRE.
3. Connect Pressure Gauge (on the end of the NTF-15 Plus coiled green hose) to the tire valve stem. Squeeze handle to fill tire. Periodically release the handle to observe the pressure level. Stop when the pressure reaches the tire manufacturer's recommended inflation pressure. **Do not over inflate.**
4. Install an RTI N<sub>2</sub> Cap (Package of 200 - Part Number 436075).



**Note:** While not using the NTF-15 Plus to fill or vacuum tires, generate Nitrogen and increase the Nitrogen pressure in the internal storage tank by turning both panel valves to STANDBY.

**Note:** While using the NTF-15 Plus, the automatic drain feature of the filters may activate to remove excess water and oil. This is normal with the standard operation of the unit.

# TESTING NITROGEN PURITY

The NitroPro Purity Tester can be used to determine the percent of nitrogen produced by the NTF-15 Plus by connecting to the Test Port. It can also be used to determine the percent of nitrogen in the air in the tires after performing a service.

Refer to the Operation Manual for the NitroPro Purity Tester (035-81169-00) for further details.



## Testing Nitrogen Purity

The tester continually releases a small amount of nitrogen from the tire when it is connected to the valve stem and while it displays the reading. This is normal.

**IMPORTANT** - this release of nitrogen will decrease the pressure in the tire. Therefore, it is important that when testing is completed that you **check the tire pressure and refill as required** to the tire manufacturer's specification.

## Helpful Hint – Purity Testing

When using the Purity Tester to measure nitrogen purity in a tire, you can minimize the pressure loss, and corresponding refill requirements, by removing the Tester from the valve stem after a sample has been obtained.

You will notice that the reading continues to climb after the Tester has been removed; this a function of the response time of the internal sensor. Once the rate of change in the reading begins to slow down or stabilize, reapply the Tester to the valve stem to obtain another sample.

This method is particularly effective at the beginning of the test procedure, when large changes in nitrogen purity readings quickly occur.



Even if you follow this method, you should **ALWAYS RECHECK THE TIRE PRESSURE** when purity testing is complete and replenish nitrogen as necessary.

# MAINTENANCE

Part	Action	Frequency
Filter Element	Replace	Yearly or when indicator on the filter head moves to the CHANGE area as shown in the illustration to the right.
Automatic Drain	Clean	When required

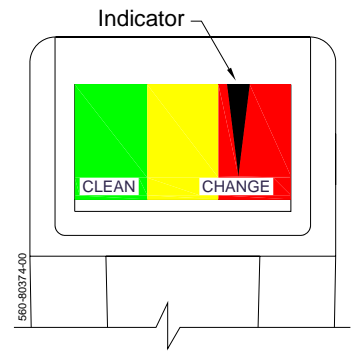

## ... IMPORTANT ...

The condition of the Filter Element (mounted on rear of unit) can only be checked when shop air is connected to the unit and it is in the FILL TIRE mode of operation with Nitrogen being generated and filling the tank. It may be necessary to press the trigger on the fill wand to cause the tank filling. At all other times the Indicator will not be visible.

The Filter Element must be changed when the indicator moves into the CHANGE area and at least annually to protect the membrane warranty.

### Replace Filter Element (Figure 1)

- Turn off the air supply.
- Let the system depressurize until the pressure gauge reads 0 psi.
- Unscrew the bleed screw (F) slowly to ensure that the filter is depressurized.
- Turn the filter bowl (E) counter-clockwise and pull the bowl from the filter housing (A).
- Unscrew the blue knob (D).
- Remove the old filter element (C).
- Clean the sieve (B) and the filter house, if necessary.
- Install a new filter element (C).
- Assemble the parts in the reverse order.

**Note:** A periodic check of the automatic drains is necessary to ensure the membrane life. To verify float is functioning correctly, open the filter bowl by turning one quarter turn counter-clockwise. Inspect for water or oil, an inactive float will be submerged, an active float will not. If float is found to be inactive follow cleaning procedure below or if necessary replace with part number 026-80386-00.

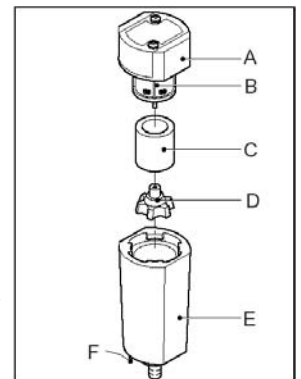

Figure 1

### Clean Automatic Drain (Figure 2)

- Open the filter by turning the bowl one quarter turn counter-clockwise.
- Unscrew the nut (F).
- Remove the drain unit (B-E) from the filter bowl (A).
- Remove the O-ring (E).
- Carefully pull the floating house (B) from the seat (D). Do not bend the needle (C).
- Clean the parts with soap and water. Make sure that the needle bore is open and clean.
- Assemble the parts in the opposite direction. Make sure that the parts are dry before reassembly.

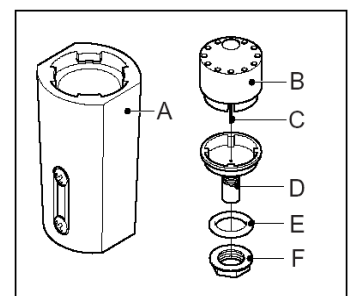

Figure 2

### Automatic Pressure Switch Setting

The automatic pressure switch is factory pre-set to shut off shop air consumption at 120 psi. This switch will then automatically reset when the N<sub>2</sub> Pressure inside the tank drops by approximately 25 psi.

If your application requires an inlet pressure of 100 - 119 psi, an adjustment to the automatic pressure switch is possible. Please contact RTI Technical Support at 800-468-2321 for further details.

# PARTS IDENTIFICATION

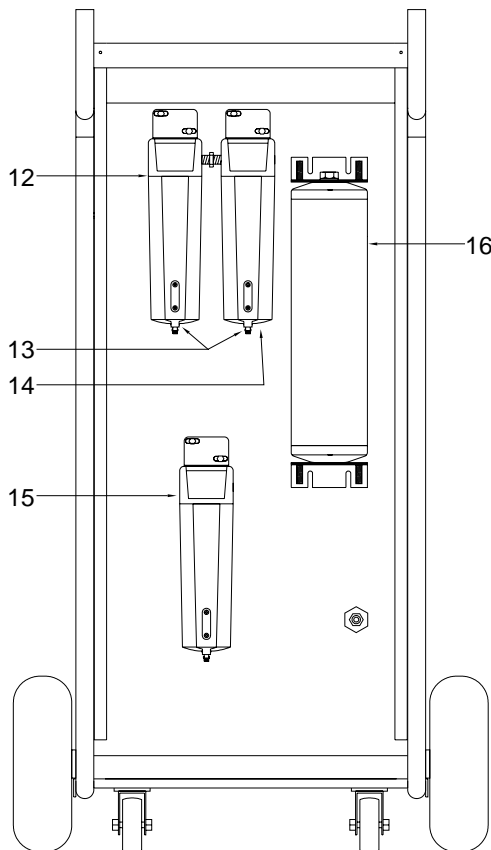
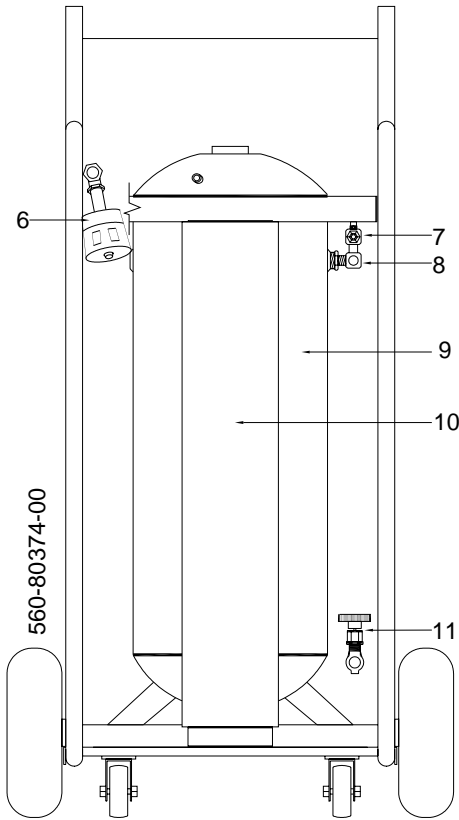
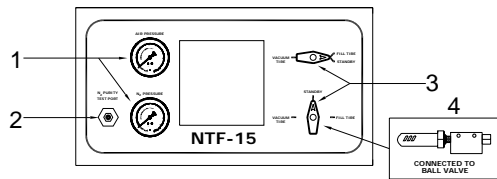

	Part Number	Description
1	026-80379-00	2 in Gauge 0-160 psig/bar 1/4MPT
2	023-80364-00	FTG Test Port 1/4 MPT X valve stem
3	022-80028-00	3-way ball valve 1/4 FPT (BHD)
4	026-80330-00	pneumatic vacuum pump
6	022-80135-00	pneumatic pilot valve
7	022-80131-00	adjustable pneumatic pressure switch
8	022-80128-00	check valve 3/8 FPT
9	022-80377-00	15 gal vertical tank
10	026-80395-00	nitrogen membrane (5.1 CFM)
11	022-80129-00	needle valve 3/8 FPT
12	026-80396-00	water filter with auto drain
13	026-80386-00	auto drain float
14	026-80397-00	oil filter with auto drain
15	026-80398-00	moisture filter
16	026-80399-00	carbon bed
17	028-80362-00	coiled green hose
18	023-80395-00	air chuck with pressure gauge

**Filter Replacement Kit**  
 355-80062-00 (Includes 16 and filters for Item 12, 14 and 15)

**N<sub>2</sub> Caps for Valve Stem (Qty=200)**  
 P/N: 436075

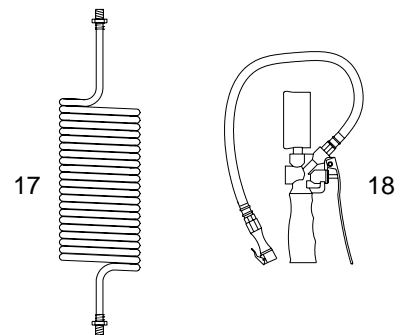

# FLOW DIAGRAM

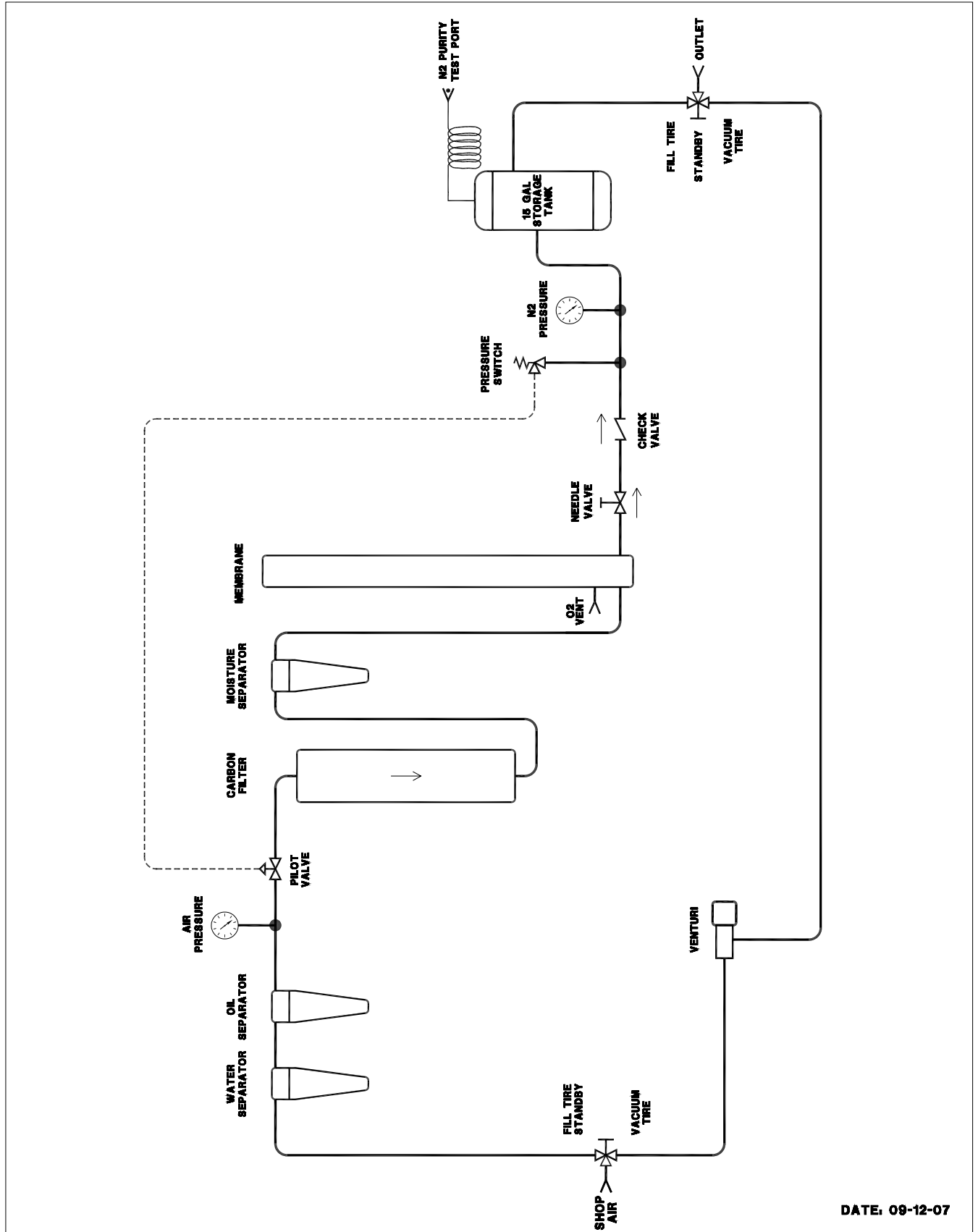

DATE: 09-12-07